



TECHNICAL FILE

ALTIRAIL LR



Distributed by

Long-span horizontal rail lifeline

ALTIRAIL LR

PRODUCT PRESENTATION

The ALTIRAIL LR rail lifeline is a rigid horizontal fall protection rail system.

Effective even at low fall heights, it is designed to secure structures where the available fixing supports are widely spaced from each other with a span of up to 8m.

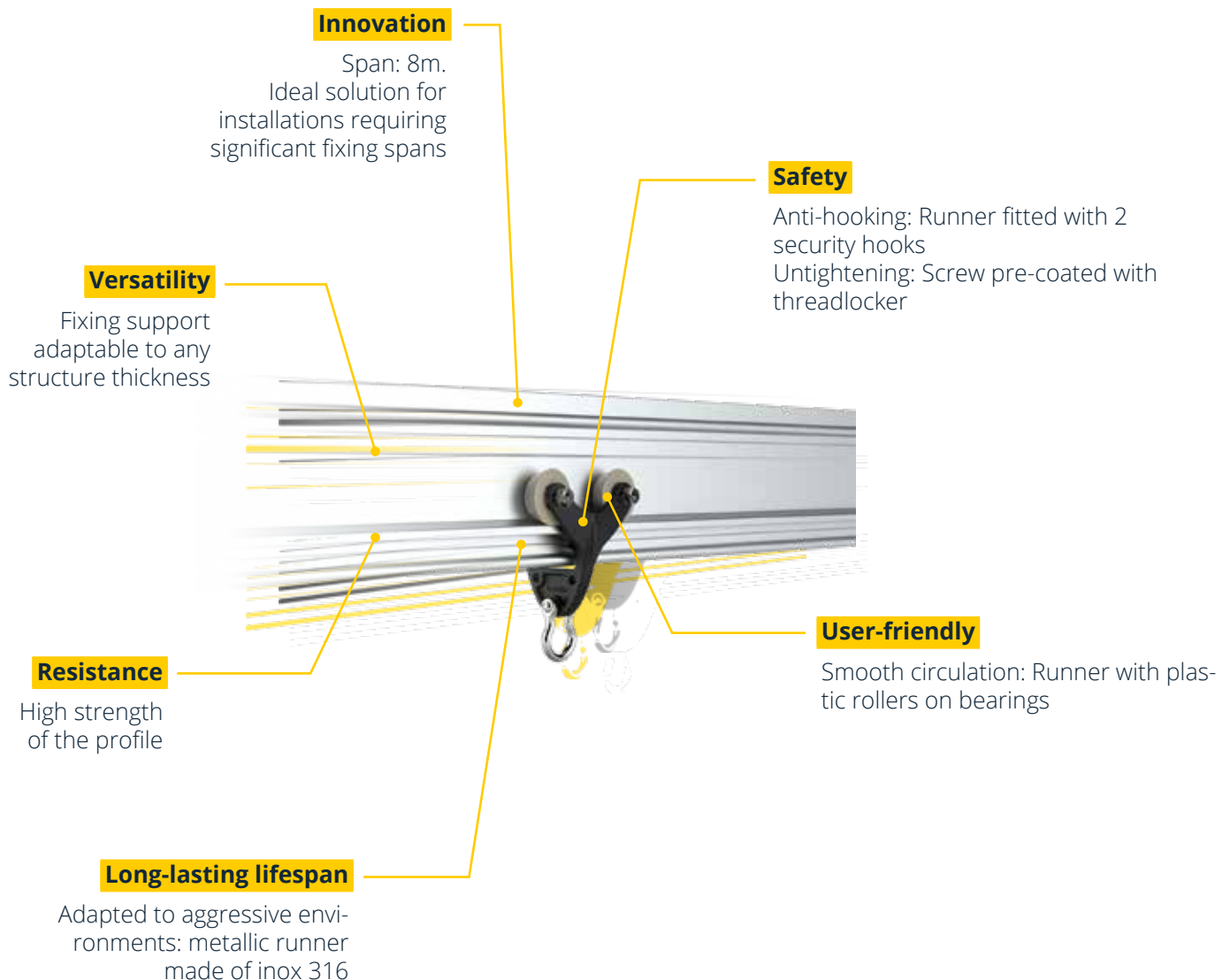



Distributed by

Long-span horizontal rail lifeline

ALTIRAIL LR

STANDARDS

This D type anchor device had been evaluated according to the standard EN 795 : 2012 "Personal fall protection equipment – anchor devices" and the technical specification TS 16415 : 2013 "Personal fall protection equipment – Anchor devices – Recommendations for anchor devices for use by more than one person simultaneously".

Mandatory - EN795:2012

- General information & construction requirements
- One minute 0.7kN deformation test at any point in the system: no permanent deformation of more than 10 mm.
- Dynamic Strength: 9kN force in all possible configurations (single span min, single span max, with angles, with intermediate parts, etc). Measuring the forces on the terminal anchors, the mobile anchor, measuring the deflection, checking that no component has broken
- Statistical Resistance: 12kN or more depending on the number of users (see TS16415 below).

Optional - TS16415: reinforcement of the tests carried out within the framework of EN 795 : 2012.

- Dynamic Resistance: 12kN force (simulating the fall of 2 users) + 9kN force (simulating an additional person), i.e., a total of 3 users.
- Statistical Resistance: 12kN force + 1kN per additional user, i.e., a total of 14kN.

USE - MAINTENANCE

The person installing the ALTIRAIL LR® rail must be a qualified person and must observe the usual rules for working at height. They must therefore ensure their safety (use of a temporary lifeline, PPE, platform, etc.).

Prior to use, the user should visually check that the ALTIRAIL LR rail is free of defects (impact, deformation, etc.).

The ALTIRAIL LR rail needs to be inspected at least once a year by a qualified person.

If the ALTIRAIL LR rail is installed incorrectly, damaged or if it has been used to arrest a fall, its use must be stopped immediately, and it must not

be used again until a competent person has given a written authorisation for its reuse, after inspection and verification.

If the product is resold outside the first country of destination, it is essential for the safety of the user that the reseller provides the instruction manual in the language of the country where the product will be used. These documents can be provided on request by contacting the manufacturer.

ALTIRAIL LR rail is a permanent means of personal protection that must be used by professionals.

If installed in a polluted industrial, petrochemical, marine or seaside environment, the ALTIRAIL LR rail must undergo an appropriate surface treatment such as powder coating, anodisation, etc.

STORAGE

The raw aluminium components are packed in contact with each other (excluding the rail).

We advise you to unpack the packages and store the components separately from each other (no contact between them), or to store the packages still packed in a sheltered and dry place.

The action of rain on unpacked packages will facilitate oxidation and degradation of the components.

Stains may also appear on the surface. This does not affect the quality of the aluminium, but it can affect the aesthetic appearance of the parts.

Linear rails are supplied in lengths of 4.40m.

The RCLR trolley is delivered in a cardboard box. We advise you to keep it in order to preserve the product and facilitate its storage. References 2 to 8 (see nomenclature below) are delivered in plastic bags with their associated screw kit.



Distributed by

Long-span horizontal rail lifeline

ALTRAIL LR

NOMENCLATURE



Rail LR
WVRRAILLR

Delivered drilled and milled.
Available in length of 4.4m. Compatible with trolleys: WVRCLR, WVRCF2 and WVRCF3.

1



Mobile runner LR
WVRCLR

Permanently installed on the rail.

2



Rail joint LR
WVRECLLR

Allows the assembly of 2 rail lengths.

3



Rail end bracket LR
WVRRBLLR

Clamps the trolley at the end and provides a perfect finish to the rail.

4



Rail end bracket for angle LR
WVRRBLR

Clamps the trolley at the end and provides a perfect finish to the rail.

5



Rail support LR
WVRSUPLR1

Allows the rail LR to align itself along the direction of the fall. Made of galvanised steel.

6



Rail support LR
WVRSUPLR2

Allows the rail LR to be fixed perpendicular to the structure. Made of galvanised steel.

7



Rail support LR
WVRSUPLR3

Allows the rail LR to be fixed parallel to the structure. Made of galvanised steel.

8



Safety sign LR
WVRPSLR

Installation at the system access point. Allows identification and monitoring of the system.

9



Angles 90° - overhead circulation
WVRA90E2 / WVRA90S2

Inner/outer corner for circulation underneath the runner.

10



Mobile runner
WVRCF2

For intensive use.

11



Mobile runner with balls
WVRCF3

For suspension work.

12



Distributed by

Long-span horizontal rail lifeline

ALTIRAIL LR

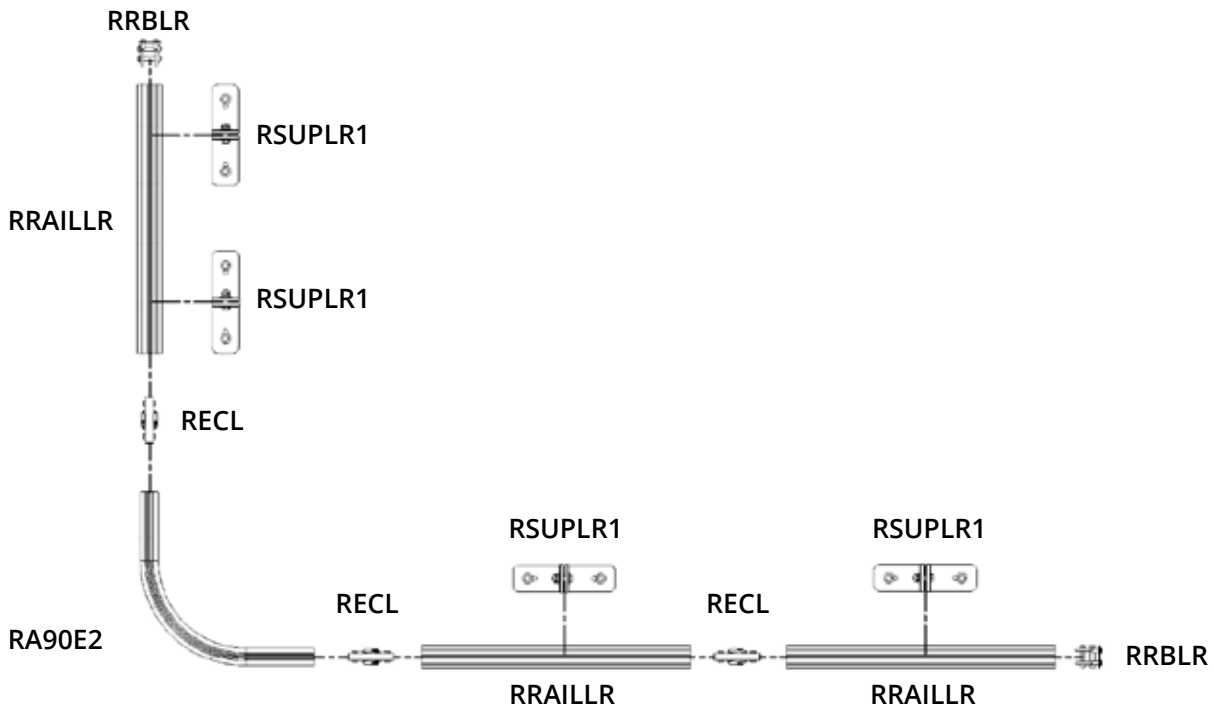



Distributed by



QUINTIN CERTIFICATIONS
1031 route de Saint Ange
38760 VARCES ALLIERES
ET RISSET - France
Tél. +33.(0)7 66 29 39 28
quintin.consult@gmail.com

CERTIFICATE OF CONFORMITY N°RQC2019-042/A

1. APPLICANT

Applicant : Mr Sébastien DUSSERT
Manufacturer : VERTIC - 691Chemin des Fontaines - CIDEX8F - 38190 BERNIN - France

2. EQUIPMENT

Type of equipment : **Anchor device type D – EN 795 : 2012 and TS 16415 :2013**
Trademark : **VERTIC**
Reference : **ALTIRAIL LR**

3. DESCRIPTION

Principales caractéristiques	Composants
<ul style="list-style-type: none"> • Use only in overhead position • Number of mobile anchor: 3 • Maximum span 8 m • Number of user : 3 people • Turn: Yes at 90° only with mobile anchor RCF2 and RCF3 • Cantilever allowed: yes, 700 mm maximum • Junction in the middle of the span allowed • End stop: only fixed end stop • Distance between anchor and turn 500 mm maximum 	<ul style="list-style-type: none"> • Rail in Aluminum 6060 T5 length 4.40 m reference RRAILLR • Mobile anchor reference RCF2 • Mobile anchor reference RCF3 • Mobile anchor reference RCLR • Terminal and intermediate anchor reference RSUPLR1 • Turn 90° in Aluminum 6060 TR reference R.A90E2 • Joint bar for rail reference RECLLR • Joint Bar for turn reference R.ECL • End stop kit reference RRBLR

(full description and results in the conformity report n°RQC2019-042-1).

4. TECHNICAL REFERENTIAL

The anchor device type D has been evaluated according to the relevant requirement of the standard EN 795 : 2012 "Personal fall protection equipment – Anchor devices" and the technical specification TS 16415 :2013 "Personal fall protection equipment – Anchor devices – Recommendations for anchor devices for use by more than one person simultaneously".

5. CONDITION OF USE

This anchor device type D is not considered as personal protective equipment against falls from a height. It is intended to be used, in combination with other components, as personal protective equipment against falls from a height.

6. CONCLUSION

The Anchor device Type D, reference **ALTIRAIL LR**, presented by **VERTIC** and described in the conformity report RQC2019-042-1, conforms to the requirements of European standard EN 795:2012 and Technical Specification TS 16415:2013.

The anchor device underwent additional static tests at 15kN 3 minutes on all the configurations tested

04/10/2019
Head of QUINTIN CERTIFICATIONS
Guillaume QUINTIN

Quintin
Guillaume Quintin



Distributed by

Long-span horizontal rail lifeline

ALTIRAIL LR

TOOLS & PERSONNEL REQUIRED

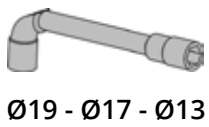

1



2

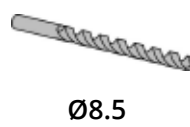

3

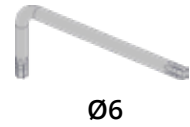

4

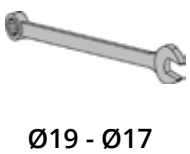

5



6



7

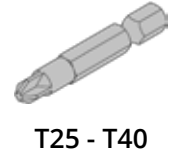

8



9



10



11

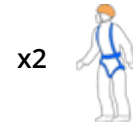

11

PREREQUISITES

TUTORIAL

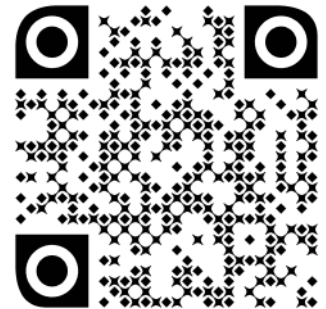
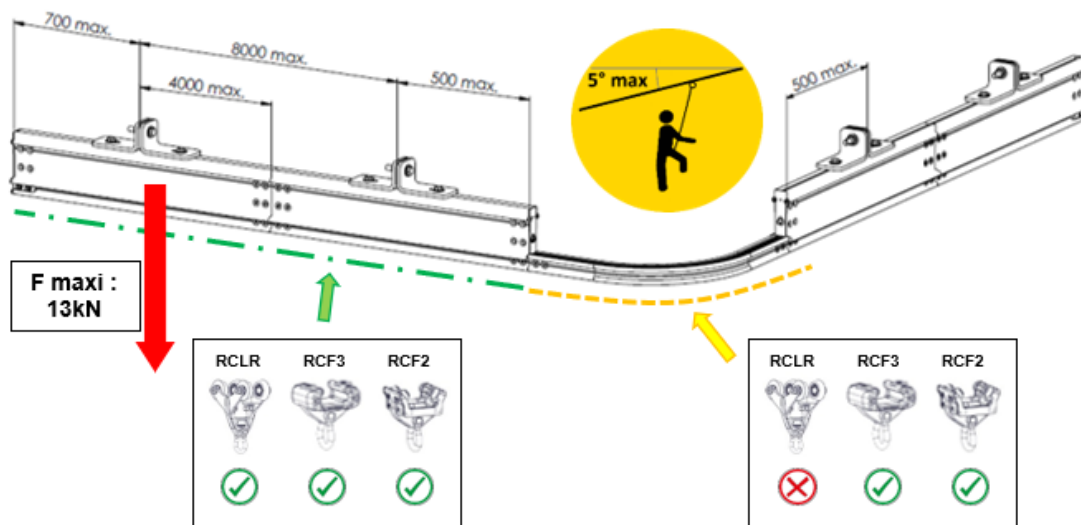



Distributed by

Long-span horizontal rail lifeline

ALTIRAIL LR

1



2

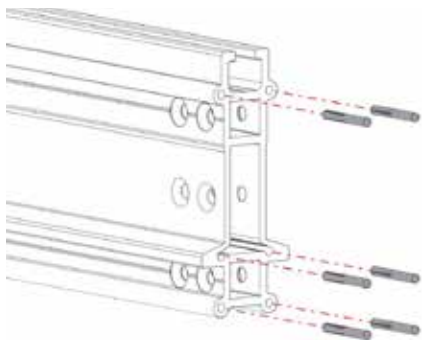

3

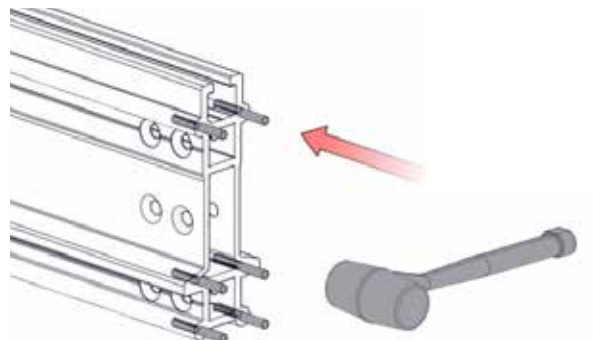

4

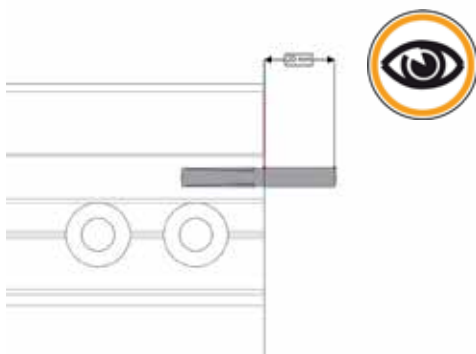

5

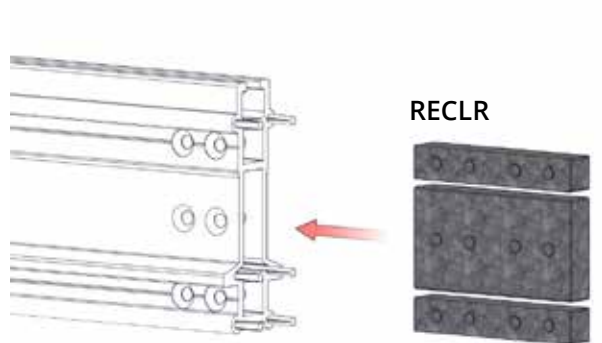



Distributed by

Long-span horizontal rail lifeline

ALTIRAIL LR

6

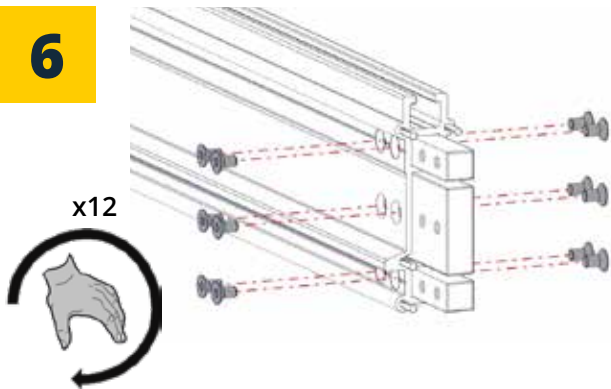

7

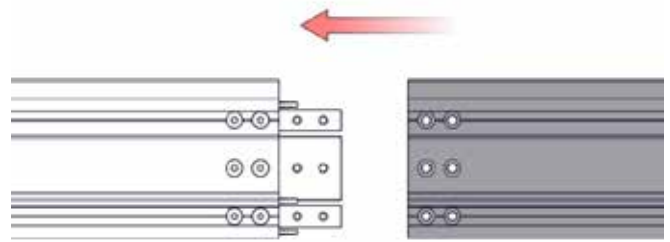

8

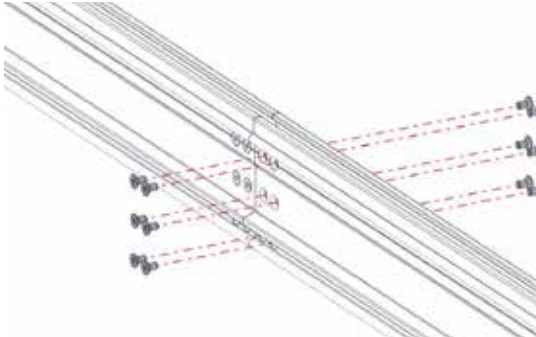

9

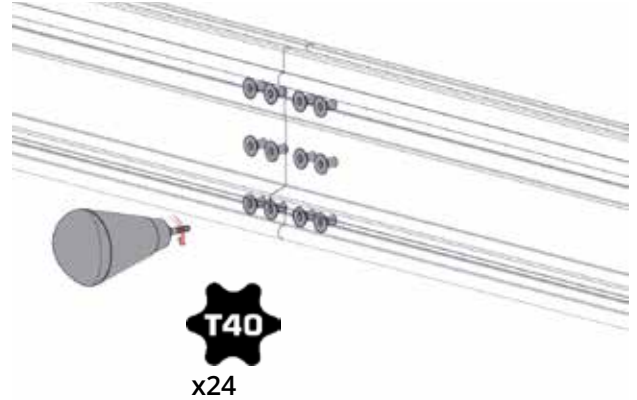

10



$B \leq 0.7m =$



$B \geq 0.7m =$





Distributed by

Long-span horizontal rail lifeline

ALTIRAIL LR

11

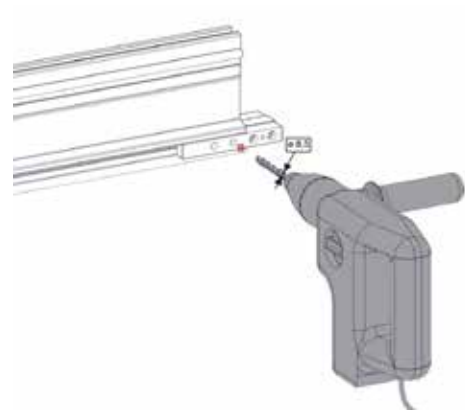
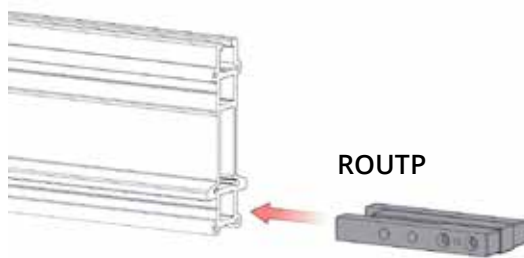

12



13

OU / OR

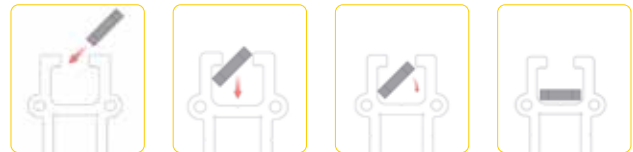

14

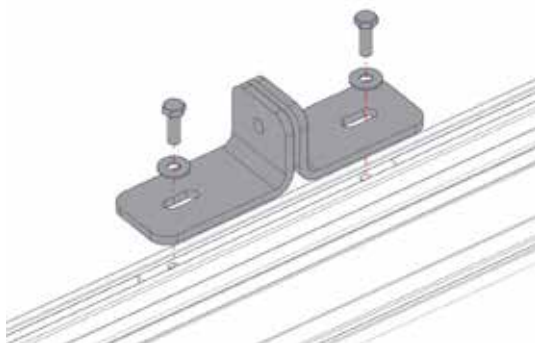

15

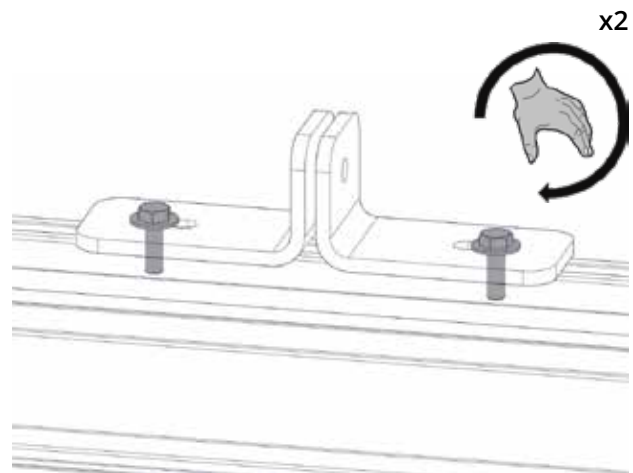



Distributed by

Long-span horizontal rail lifeline

ALTIRAIL LR

16



17

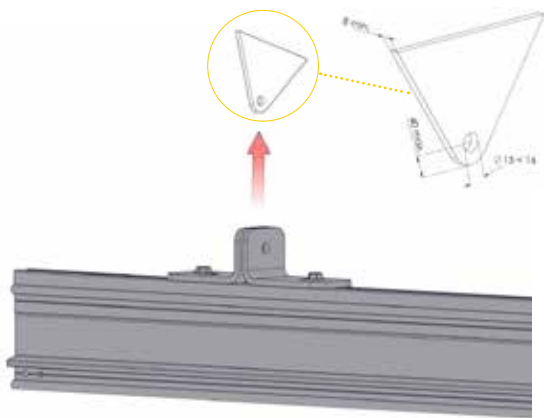

18

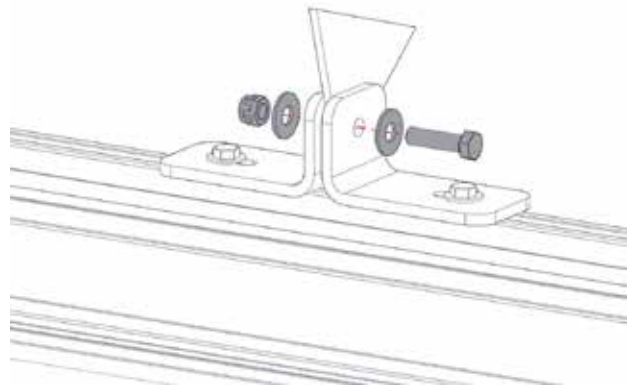

19

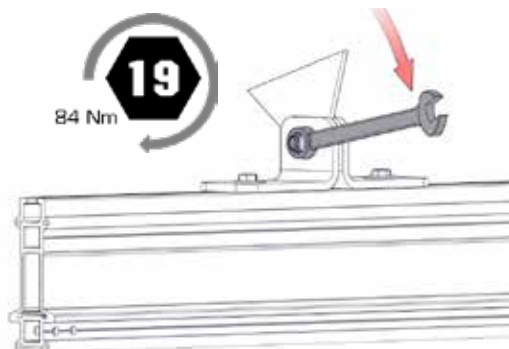

20

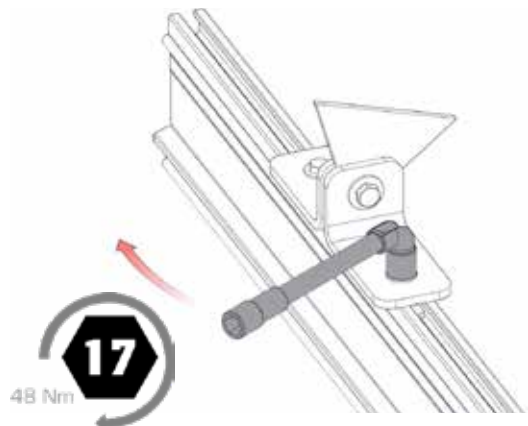



Distributed by

Long-span horizontal rail lifeline

ALTIRAIL LR

21

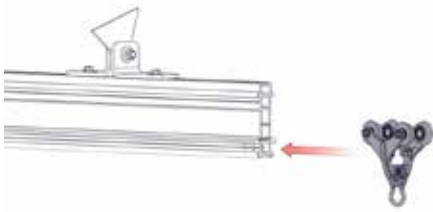

22

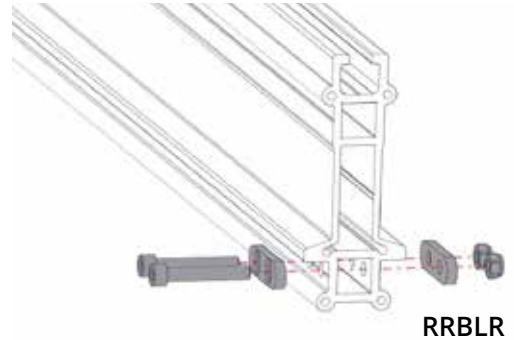

23

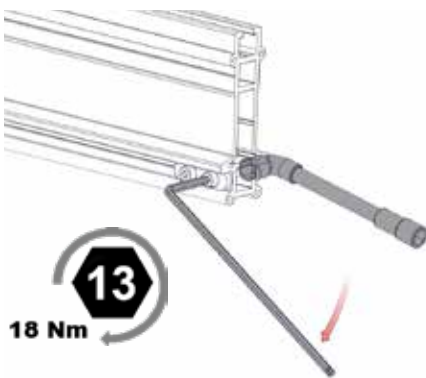

24

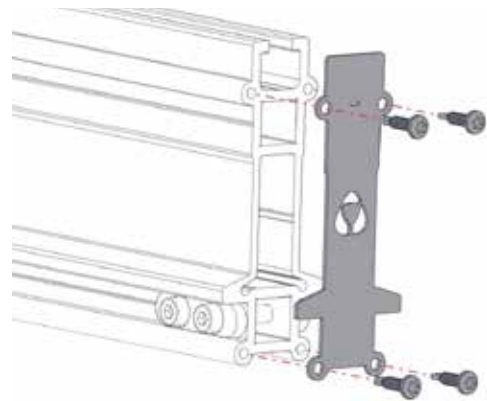

25

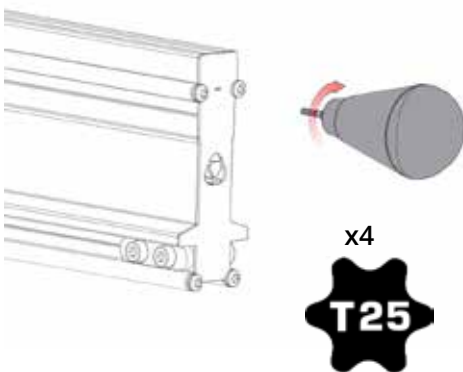



Distributed by

Long-span horizontal rail lifeline

ALTIRAIL LR

Procédure de montage R.A90
Procedure of assembly R.A90
Procedimiento de montaje R.A90
Installatie procedure voor R.A90
Montageanleitung auf einer R.A90
Procedura di montaggio su R.A90
Procedimento de montagem em R.A90

Prérequis
Requirements
Pre-requisito
Vereisten
Voraussetzungen
Prerequisiti
Requisitos



1

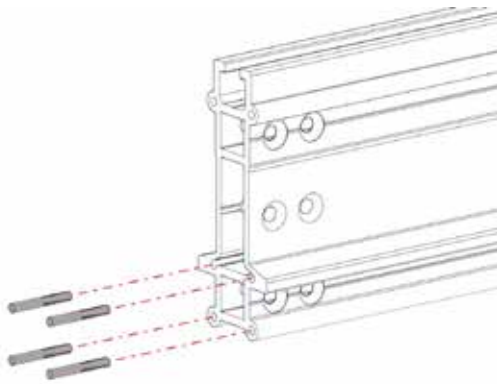

2

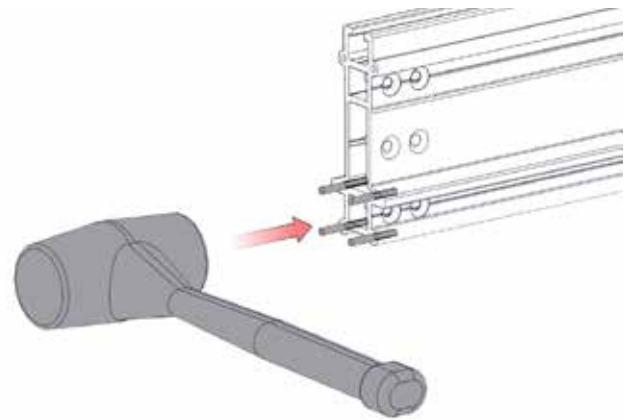

3

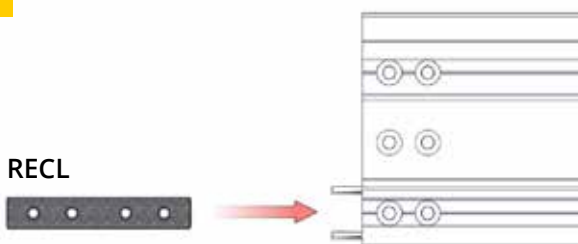

4

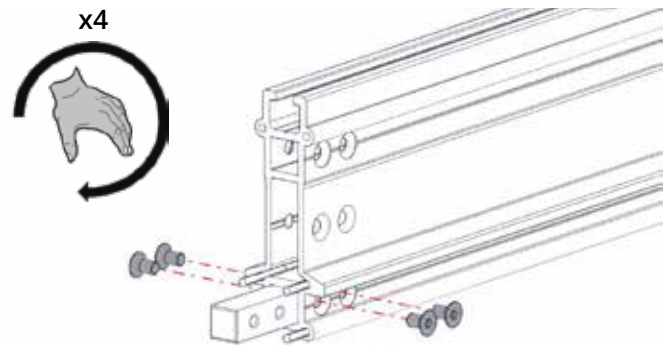



Distributed by

Long-span horizontal rail lifeline

ALTIRAIL LR

5



6

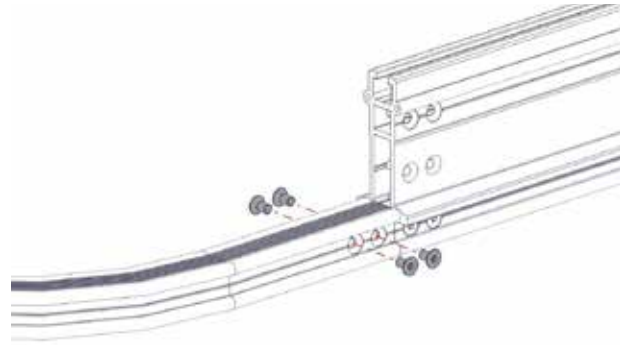

7

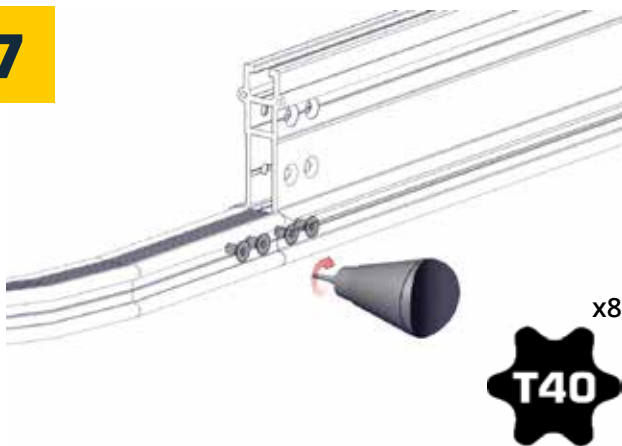

8

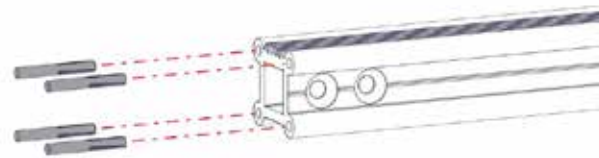

9

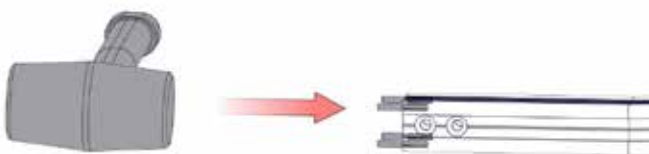

10





Distributed by

Long-span horizontal rail lifeline

ALTIRAIL LR

11

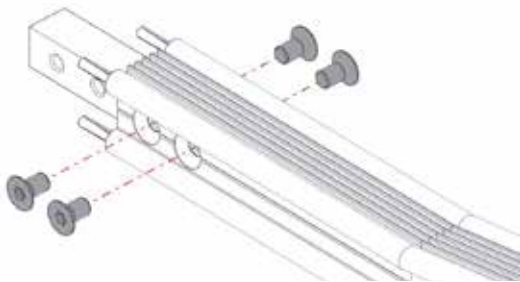

12

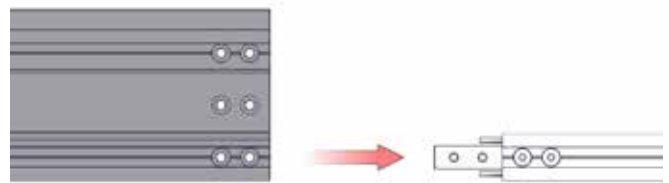

13

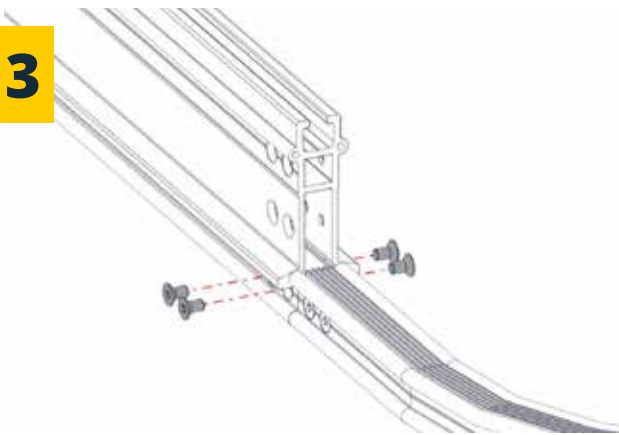

14

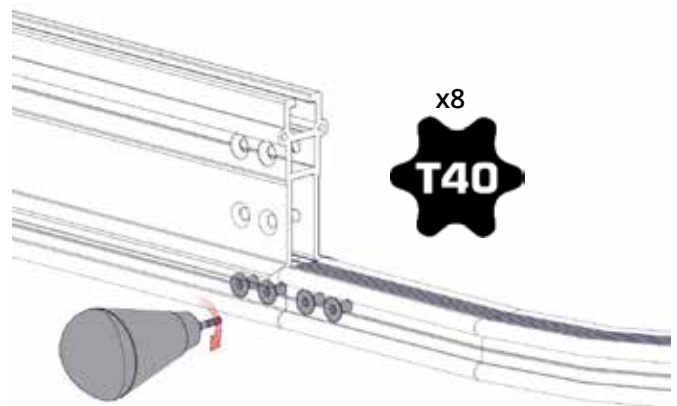

15

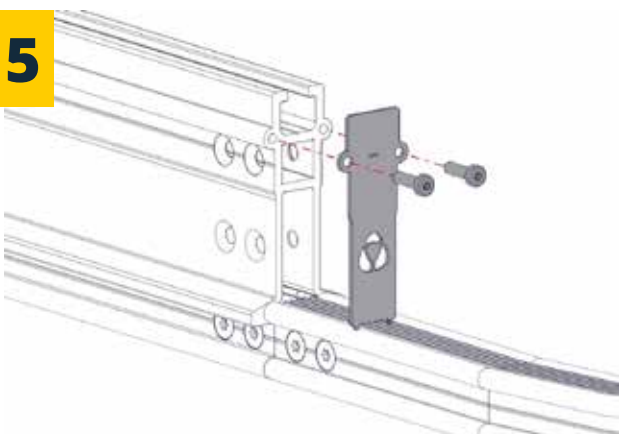

16

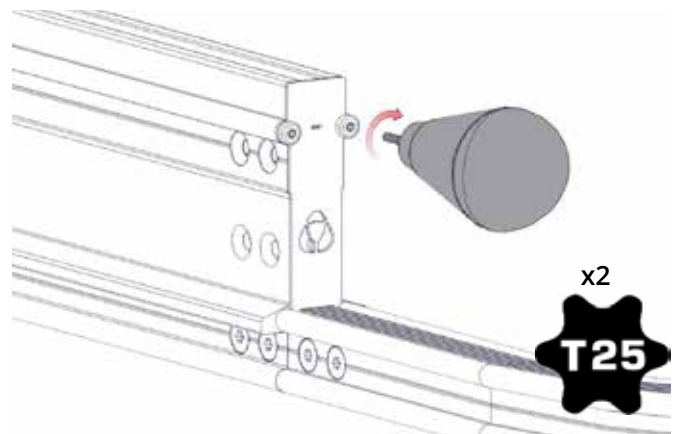



Distributed by

Long-span horizontal rail lifeline

ALTIRAIL LR

SIGNS & MARKING



1

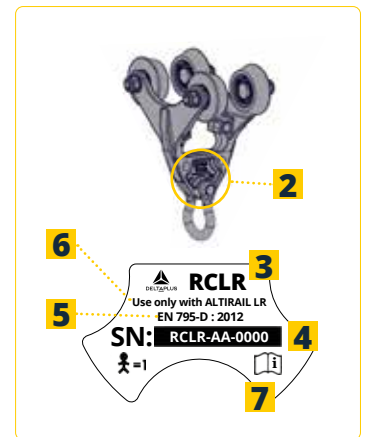
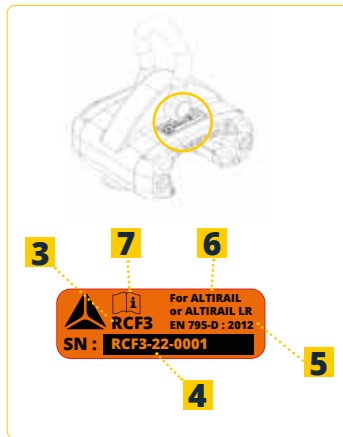
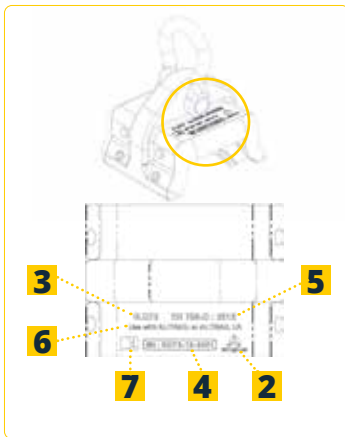
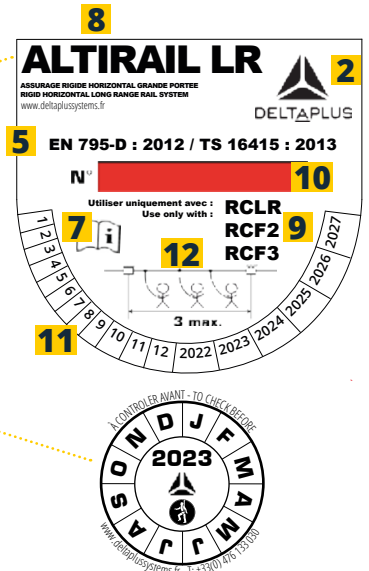
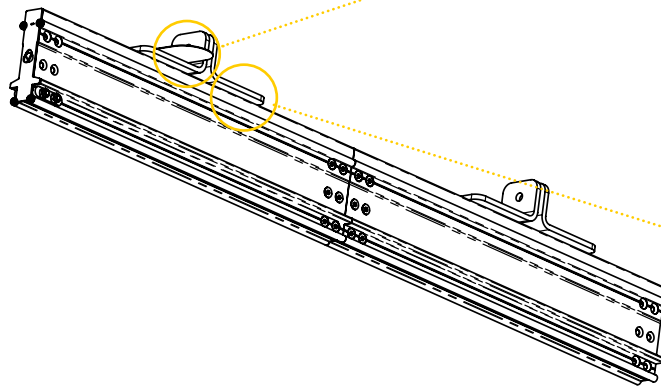

- | | | |
|--|---|--|
| 1 Wearing of PPE is mandatory | 2 Manufacturer's name | 3 Mobile anchor point reference |
| 4 Serial number of the mobile anchor point | 5 Standard to which the equipment conforms | 6 Compatible anchor line reference |
| 7 Pictogram inviting to read the instructions | 8 Anchor line reference | 9 Compatible mobile anchor point reference |
| 10 Anchor line serial number | 11 Date of first use | 12 Maximum number of persons authorised to connect simultaneously |
| 13 Date of periodic inspection | | |



Distributed by

Long-span horizontal rail lifeline

ALTIRAIL LR

PRINCIPLE OF USE

If the direction of fall is at an angle to the rail, the rail must be installed in such a way that it can be rotated to the axis of the fall, no parts must impede this movement and no corner pieces must be used.

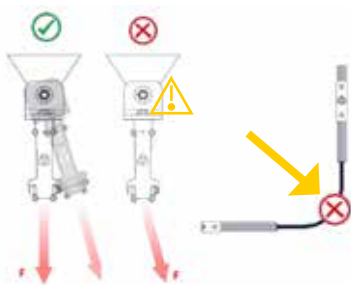

INFORMATION

This sheet is intended for users of the ALTIRAIL LR anchor line and its mobile anchors WVRCLR, WVRCF2 or WVRCF3. It must be read and understood by each person before using the product. If you have any doubts, problems of understanding, or if a problem arises that is not covered in this document, please contact your Delta Plus Systems representative or the Delta Plus Systems technical department directly. These instructions must always be available and accessible to the user. If the product is resold outside the first country of destination, it is essential for the safety of the user that the dealer provides the instructions for use, maintenance, periodic examinations as well as instructions for repairs, written in the language of the country where the product is used. Any activity at a height is dangerous and can cause accidents, serious injury or death. The practice, as well as learning the techniques of using the appropriate equipment, is your responsibility. Before using the product, you must therefore read and understand all the information contained in the instructions for use. Non-compliance with any of these warnings may result in serious injury or death. For safety reasons, the user must be in good health, not under the influence of medication, alcohol or drugs. Workers using personal protective equipment should receive appropriate training.

INSTALLATION

For safety reasons, it is essential that the ALTI-RAIL LR anchor line is always correctly positioned, and that work is carried out in a way that minimises the risk and height of fall.

It is also important to check the clearance required under the user in the workplace, so that in the event of a fall, there is no collision with the ground or other obstacle in the path of the fall. The anchor must therefore be installed taking into account all these safety parameters. Installation of the product must be carried out by installers authorised or trained by Delta Plus Systems. Installers must ensure that the support materials in which structural anchors are fixed are suitable. Delta Plus Systems cannot be held responsible for the incorrect installation of an ALTIRAIL LR anchor line.

A schematic plan should be affixed to the building so that it is visible to all.

It is also necessary that the declarations made by the responsible installer are signed by him and certify at least that the anchoring device:

- Has been installed in accordance with the manufacturer's installation instructions
- Complies with the plan
- Has been fixed on the specified support
- Has been fixed as specified (for example, number of bolts, correct materials, correct position/location).

Where several anchor points are to be photographed for identification purposes, it is recommended that the anchor devices are marked with numbers and that this numbering is incorporated into the anchor device inspection records and the ground plan of the installation area.

If the marking of the anchoring device is not accessible after installation, an additional marking near the anchoring device is recommended.

INSTRUCTIONS FOR USE & TECHNICAL DESCRIPTION

The anchor line and the compatible anchor points form an anchoring system that does not deviate from the horizontal by more than 15° and complies with EN 795 class D: 2012 and CEN/TS 16415: 2013.

This system is intended to stop the fall of one or more persons and must not be used to lift loads.

Several people can simultaneously use the anchor line rail. For this purpose, each user must have his own trolley.

The system must be used in conjunction with a compliant P.E.I. assembly compatible with the on-site configuration, which must not be damaged so as not to affect the safety function of the system.

Only use a safety harness that complies with EN 361 and one of the connections recommended on the sign:

- EN362 compliant connector
- Lanyards compliant with EN 354 combined with an EN 355 energy absorber
- Fall arrest system compliant with EN 353-2/EN 360.



Distributed by

Long-span horizontal rail lifeline

ALTIRAIL LR

SIGNS & MARKING

This connection must not cause a peak force of more than 6 kN in the event of a fall. An incompatible connection may lead to accidental disconnection, breakage or affect the safety function of other equipment. When you are at a height, your life depends on the equipment you use. Any doubts about the safety of the device should be reported to the manufacturer and the person responsible for the installation. After a fall, do not use the trolley or the system until it has been checked and rendered compliant again by a competent person authorised by the manufacturer.

The distance of the fall arrest link used should be compatible with the available air draught of the site.

Fall clearance calculation:

- 1** Fall Clearance Available
- 2** Lanyard length
+ extension of the energy absorber
+ user's size
- 3** Safety distance (1m)

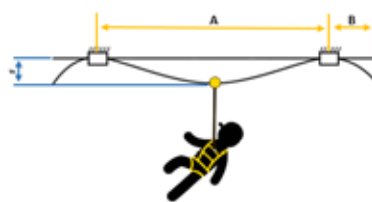
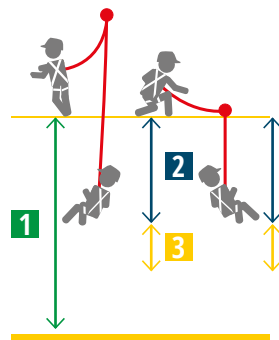

	A (m)	B (m)		
	8	6	4	0.7
F (mm)	600	500	300	50

If an adjustable connector is used, the user should make sure that the length is optimised in order to limit the possible fall height and reduce the risk of injury. The user must connect the harness to the mobile anchorage point using the sternal fastening point. The trolley has been designed to move freely on the rail without manual intervention.

There is no limit to the length of the anchor line. All points on the rigid anchor line, at which the mobile fall arrester could exit must be equipped with an WVRBRLR stop.

Where the installation requires the use of WVRA90E2 angles, only the use of WVRCF2 or WVRCF3 anchor points is permitted. The WVRCLR anchor point must not be used in combination with the WVRA90E2 angle.

Mobile fall arresters with stainless steel components should not be installed in highly corrosive atmospheres (e.g., above a swimming pool) due to the risk of invisible stress corrosion cracking, unless specific control measures are implemented, or compatibility is established. It is important to check the compatibility of nylon castors in case of use in specific environments (presence of acids or halogen, etc.).

IMPORTANT – PREVENTION BEFORE USE:

Ensure that all ends of the anchor lines have a stopper, that the mobile trolley rolls freely along the line and that the shackle rotates freely in the body of the trolley.

Carry out a regular periodic review of the entire equipment using the identification and verification sheets for your products.

When you are at a height, your life depends on the equipment you use. Any doubts about the safety of the device should be reported to the manufacturer and the person responsible for the installation.

A fall arrest harness conforming to EN 361 is the only body-gripping device that may be used in a fall arrest system. A harness must be suitable for the user's height and properly adjusted. The fall arrest harness should be properly adjusted to fit snugly and should not be used if it is loose. If the harness becomes loose while in use, it should be properly readjusted from a safe location. The durability of the line must be checked in accordance with the use.

The product must not be used beyond its limits, or in any other unintended situation.

Before use, a rescue plan should be in place to deal with any emergencies that may arise during work. Before and during use, consideration should naturally be given to ensure that any possible rescue is carried out effectively and safely. In a rescue situation, the rigid anchor line offers sufficient strength to allow rescue operations.

In a fall arrest system, it is essential to check the clearance under the user before and during use, in order to avoid any collision with the ground or an obstacle during the fall.

The system can be used for suspension work. In such cases, the use of two mobile anchors is mandatory in accordance with article R4323-89 of the Labour Code. (use not covered by EN 795).

A hazard may arise when using several pieces of equipment in which the safety function of one piece of equipment may be affected by the safety function of the other.



Distributed by

Long-span horizontal rail lifeline

ALTIRAIL LR

Use only Delta Plus Systems parts to ensure compatibility of parts when assembling the system.

CONTROL - POINTS TO BE CHECKED

Make sure that the instructions for using the safety rail are displayed on the safety rail panel. Make sure that the product markings are legible. Make sure that the fall arrest system you have is compliant and compatible with those recommended. Make sure that the periodic checks and maintenance of the safety rail are up to date. Carry out a visual and functional check of the entire safety rail and trolley. Use the System Identification and Verification Sheet to perform these checks. For each installation, a qualified person must verify and certify that the anchor device is suitable for the area to be secured and compatible with the strength of the structure and interfaces on which it is installed. This verification can be done through calculation or testing. Particular attention should be paid to the choice of fasteners.

The maximum force transmitted to the structure in the event of a fall is 13kN. The strength of the anchor device is directly related to the quality of the line. Its conformity can only be established if the materials constituting the line are free from any manufacturing defect or drop in performance (ageing, overload, corrosion, etc.).

After a fall, do not use the system until it has been checked and rendered compliant again by a competent person authorised by the manufacturer.

LIFE SPAN - DISPOSAL

The products are guaranteed against any material or manufacturing defect for a period of 10 years from the date of delivery for metal parts, the guarantee is 2 years for other parts (textile, plastic, electrical and electronic components, etc.).

CAUTION, an exceptional event may lead you to dispose of a product after single use (type and intensity of use, environment of use: aggressive environments, marine environment, sharp edges, extreme temperatures, chemical products, etc.).

A product must be disposed of when:

- It is over 10 years old and made of plastic or textile.
- It has had a major fall (or blow).
- The result of the product verification is not satisfactory.
- You doubt its reliability.
- You do not know its full usage history.
- Its use is obsolete (legislative, normative, technical or incompatibility with other equipment, etc.).

Destroy such products to prevent future use.

SYSTEM WARRANTY

The warranty starts on the date of delivery of the equipment or installation by Delta Plus Systems. It lasts for 10 years for metal parts and 2 years for other parts, provided that annual maintenance has been carried out by our own inspection teams or any other company approved by Delta Plus Systems. Delta Plus Systems guarantees this product against material or manufacturing defects.

The following are excluded from the warranty: normal wear and tear, oxidation, modifications or repairs, improper storage, improper maintenance, damage due to accidents, negligence, or use for which the product is not intended.

MAINTENANCE & SERVICE

Any modification or addition to the equipment without the prior written consent of the manufacturer is prohibited.

Any repairs to system components must be carried out in accordance with Delta Plus Systems procedures. If in doubt about the condition of the product, replace it with an original Delta Plus Systems part.

A soiled product should be washed and rinsed with clean water and then dried, keeping it away from any direct source of heat. It must not be in contact with corrosive or aggressive materials or stored at extreme temperatures. Any chemicals or solvents may affect the strength of the system components. If the product is likely to come into contact with these products, please let us know the exact name of the chemical components and we will respond after appropriate investigation.

It is mandatory to have the condition of the anchor systems checked at least every 12 months by an authorised and competent person in strict accordance with Delta Plus Systems' operating procedures. These periodic and regular inspections are necessary because the safety of the user is linked to maintaining the efficiency and strength of the equipment. The inspection and its results must be recorded in writing in a maintenance logbook using the identification and inspection sheet provided by Delta Plus Systems.

Delta Plus Systems can also carry out all these maintenance and inspection operations.



Distributed by

Long-span horizontal rail lifeline

ALTIRAIL LR

FALL ARREST RAIL ALTIRAIL LR - WVRRAILLR

Product identification

Manufacturer - Supplier	Delta Plus Systems
Product name - Reference	Altirail LR - RRAILR
Identification number	EN795 : 2012 + CEN/TS16415 : 2013
Date of purchase	
Date of first use	



Installation manager's identification

Name |
Company |

User identification

Name |
Address |

LIFESPAN - DISPOSAL

BEFORE USE:

For Delta Plus Systems' plastic and textile products, the maximum lifespan is 10 years from the date of manufacture. It is not limited for metallic products.

CAUTION, an exceptional event may lead you to dispose of a product after single use (type and intensity of use, environment of use: aggressive environments, marine environment, sharp edges, extreme temperatures, chemical products, etc.).

A product must be disposed of when:

- It is more than 10 years old and is made of plastic or textile, except for the seals, which should be inspected regularly.
- It has had a major fall (or blow).
- The result of the product verification is not satisfactory.
- You doubt its reliability.
- You do not know its full usage history.
- Its use is obsolete (legislative, normative, technical or incompatibility with other equipment, etc.).

Destroy such products to prevent future use.

LEGEND



Comments



To be monitored



To be repaired



Good



For destruction





Distributed by

Long-span horizontal rail lifeline

ALTIRAIL LR

VISUAL CHECK OF COMPONENTS



General condition of the aluminium rail (marks, deformations, corrosion, etc.)					
Condition of fasteners and anchors (tightness, corrosion, etc.)					
The fastening interval of the WVRSUPLR rail anchors does not exceed 8 metres					
The maximum overhang distances of the rail have been respected (max 700mm)					
The rail is in a horizontal position (<math><5^\circ</math>) and in the right direction (groove open upwards)					
There is no play in the bolted joints and all screws are present and tight					
Presence of markings with normative information					
Presence of end stoppers					

FUNCTIONAL CHECK OF COMPONENTS



The runners WVRCLR, WVRCF3, WVRCF2 run smoothly over the bolted joints and supports					
The anchor lines with an angle (WVRA90) are not connected to an WvrCLR runner.					
Good location of the anchor point in relation to the area to be secured					

COMMENTS

VERDICT OF INSPECTION

<input type="checkbox"/> The product can remain in use	<input type="checkbox"/> The product cannot remain in use
---	--

IDENTIFICATION & CONTROLLER VISA

Name	
Company	
Date of control	
Date of next control	
Controller's stamp (company/stamp)	



Distributed by

Long-span horizontal rail lifeline

ALTIRAIL LR

MOBILE RUNNER FOR ALTIRAIL LR - WVRCLR

Product identification

Manufacturer - Supplier	Delta Plus Systems
Product name - Reference	Mobile runner WVRCLR
Identification number	EN795 : 2012 - Class D
Date of purchase	
Date of first use	



Installation manager's identification

Name
Company

User identification

Name
Address

LIFESPAN - DISPOSAL

BEFORE USE:

For Delta Plus Systems' plastic and textile products, the maximum lifespan is 10 years from the date of manufacture. It is not limited for metallic products.

CAUTION, an exceptional event may lead you to dispose of a product after single use (type and intensity of use, environment of use: aggressive environments, marine environment, sharp edges, extreme temperatures, chemical products, etc.).

A product must be disposed of when:

- It is more than 10 years old and is made of plastic or textile, except for the seals, which should be inspected regularly.
- It has had a major fall (or blow).
- The result of the product verification is not satisfactory.
- You doubt its reliability.
- You do not know its full usage history.
- Its use is obsolete (legislative, normative, technical or incompatibility with other equipment, etc.).

Destroy such products to prevent future use.

LEGEND



Comments



To be monitored



To be repaired



Good



For destruction





Distributed by

Long-span horizontal rail lifeline

ALTIRAIL LR

VISUAL CHECK OF COMPONENTS



Condition of the body (cracks, marks, deformations, wear, corrosion)					
Condition of the shackle and its axis (cracks, marks, deformation, wear, corrosion)					
Condition of the 4 castors (deformation, cracks, wear)					
Presence of the 4 circlips					
Check the tightness of the 4 nuts					
Presence of identification markings with normative information on the runner					

FUNCTIONAL CHECK OF COMPONENTS



180° tilting of the stainless steel shackle (no hard points)					
Good rolling of the ball bearings (no hard points, fluidity, no noise or vibration)					
No play in the ball bearings					
The runner runs evenly on a straight rail element					

COMMENTS

VERDICT OF INSPECTION

<input type="checkbox"/> The product can remain in use	<input type="checkbox"/> The product cannot remain in use
---	--

IDENTIFICATION & CONTROLLER VISA

Name	
Company	
Date of control	
Date of next control	
Controller's stamp (company/stamp)	